

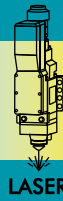

TOOLS

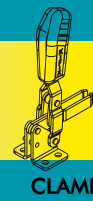

LASER



CLAMPS

Kifix[®]
GROUP

KIFIX ADAPTADORES ADAPTERS

agj

PARA MESAS DE SOLDADURA

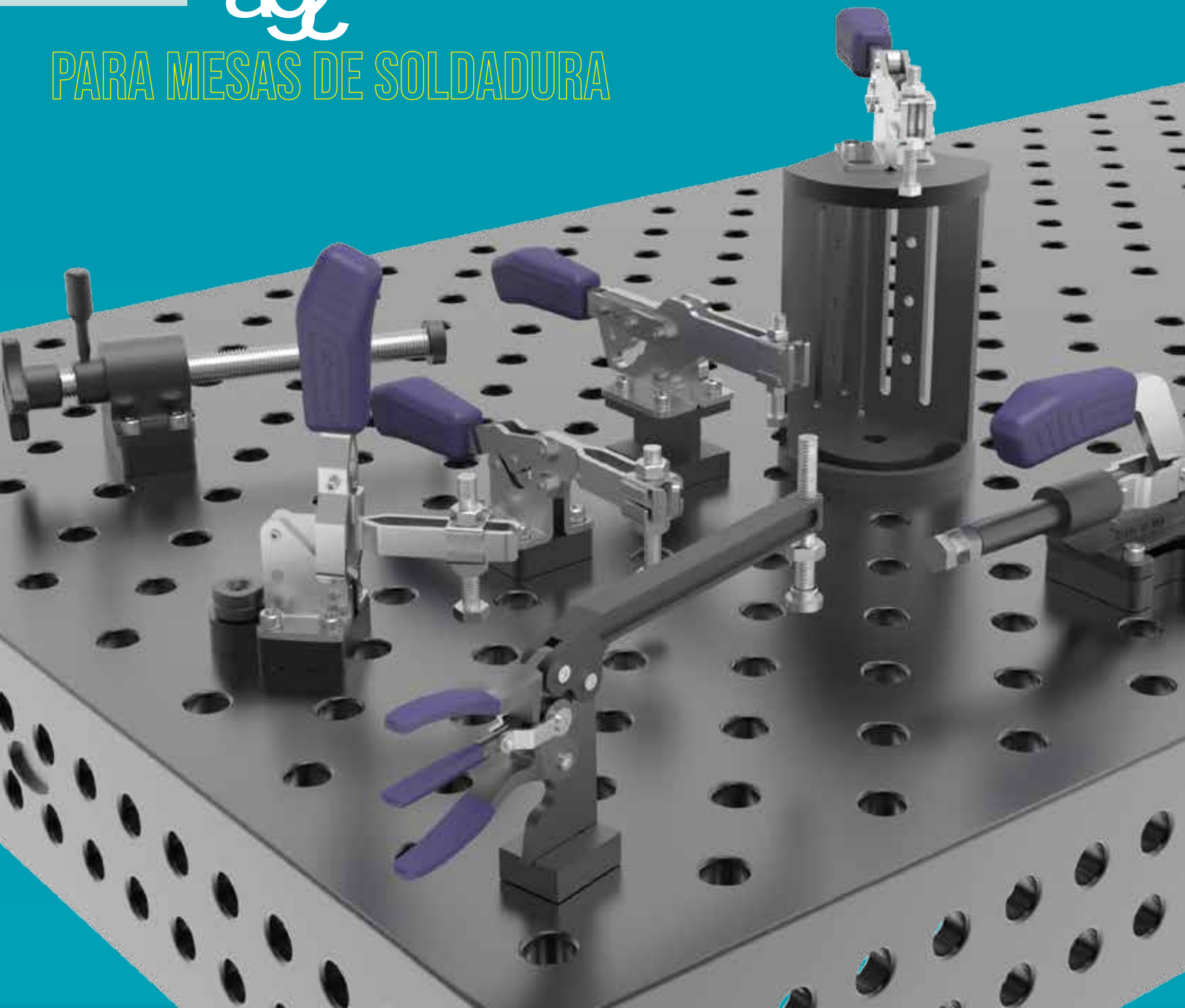

BASE SURÉLEVÉE

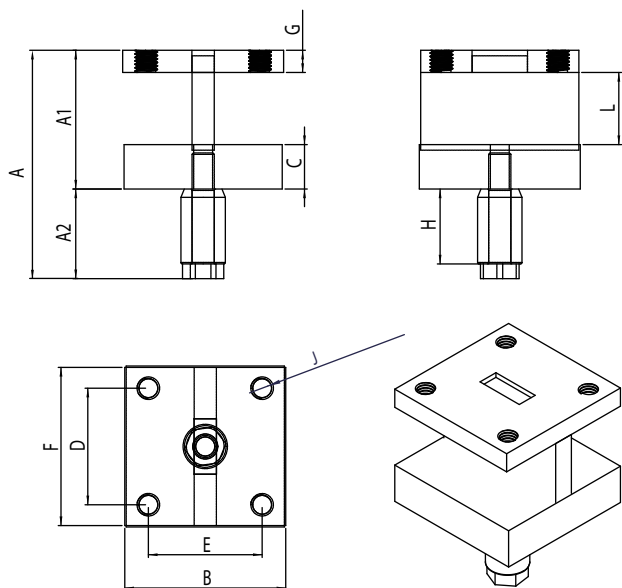

MS BE Ø 22 H50 - KF-532/528

MS - Table de soudage
BE - Base Surélevée
H - Hauteur

REFERENCE	Referencia	A (IN)	A1 (IN)	A2 (IN)	B (IN)	C (IN)	D (IN)	E (IN)	F (IN)	G (IN)	H (IN)	J (IN)	L (IN)	WEIGHT KG (LB)
Peso														
MS BE Ø 16 H50 - KF-532/528		82,3 (3,24)	50 (1,96)	32,3 (1,27)	58 (2,28)	16 (0,62)	42 (1,65)	41 (1,61)	57 (2,24)	8 (0,31)	27 (1,06)	M8	26	0,76 (1,67)
MS BE Ø 22 H50 - KF-532/528		88,4 (3,48)	51 (1,96)	36,4 (1,43)	58 (2,28)	16 (0,62)	42 (1,65)	41 (1,61)	57 (2,24)	8 (0,31)	30 (1,18)	M8	26	0,82 (1,80)
MS BE Ø 28 H50 - KF-532/528		95,5 (3,75)	52 (1,96)	42,5 (1,67)	58 (2,28)	16 (0,62)	42 (1,65)	41 (1,61)	57 (2,24)	8 (0,31)	35 (1,37)	M8	26	0,91 (2,00)
MS BE Ø 16 H75 - KF-532/528		107,3 (4,22)	75 (2,95)	32,3 (1,27)	58 (2,28)	16 (0,62)	42 (1,65)	41 (1,61)	57 (2,24)	8 (0,31)	27 (1,06)	M8	51	0,85 (1,87)
MS BE Ø 22 H75 - KF-532/528		111,4 (4,38)	75 (2,95)	36,4 (1,43)	58 (2,28)	16 (0,62)	42 (1,65)	41 (1,61)	57 (2,24)	8 (0,31)	30 (1,18)	M8	51	0,914 (2,01)
MS BE Ø 28 H75 - KF-532/528		117,5 (4,62)	75 (2,95)	42,5 (1,67)	58 (2,28)	16 (0,62)	42 (1,65)	41 (1,61)	57 (2,24)	8 (0,31)	35 (1,37)	M8	51	0,995 (2,19)
MS BE Ø 16 H100 - KF-532/528		132,3 (5,20)	100 (3,93)	32,3 (1,27)	58 (2,28)	16 (0,62)	42 (1,65)	41 (1,61)	57 (2,24)	8 (0,31)	27 (1,06)	M8	78	0,942 (2,07)
MS BE Ø 22 H100 - KF-532/528		136,4 (5,37)	100 (3,93)	36,4 (1,43)	58 (2,28)	16 (0,62)	42 (1,65)	41 (1,61)	57 (2,24)	8 (0,31)	30 (1,18)	M8	78	1,005 (2,21)
MS BE Ø 28 H100 - KF-532/528		145,5 (5,72)	100 (3,93)	42,5 (1,67)	58 (2,28)	16 (0,62)	42 (1,65)	41 (1,61)	57 (2,24)	8 (0,31)	35 (1,37)	M8	78	1,085 (2,39)

VARIABLE STROKE BASE BASE HUSILLO RÁPIDO

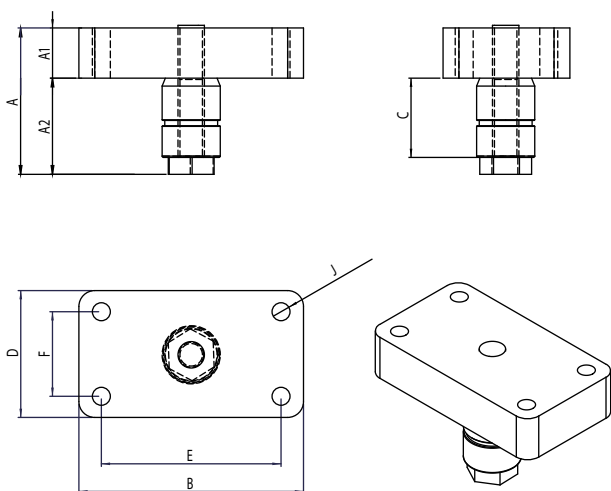

MS FU Ø 22 - KFRL-20

MS - Welding table MS - Mesa de soldadura
FU - Variable Stroke FU - Husillo rápido

REFERENCE	Referencia	A (IN)	A1 (IN)	A2 (IN)	B (IN)	C (IN)	D (IN)	E (IN)	F (IN)	J (IN)	WEIGHT KG (LB)
Peso											
MS FU Ø 16 - KFRL-20		48,3 (1,90)	16 (0,62)	32,3 (1,27)	85 (3,34)	27 (1,06)	48 (1,88)	68 (2,67)	32 (1,25)	M8	0,542 (1,19)
MS FU Ø 22 - KFRL-20		55,4 (2,18)	19 (0,74)	36,4 (1,43)	85 (3,34)	30 (1,18)	48 (1,88)	68 (2,67)	32 (1,25)	M8	0,695 (1,53)
MS FU Ø 28 - KFRL-20		67,9 (2,67)	25,4 (1,00)	42,5 (1,67)	85 (3,34)	35 (1,37)	48 (1,88)	68 (2,67)	32 (1,25)	M9	0,954 (2,10)

TABLE TOWER TORRE MESA

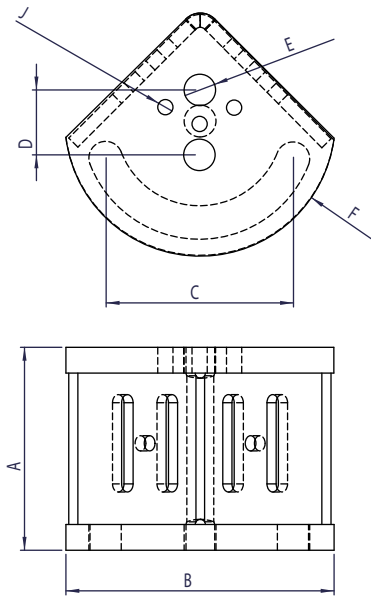

MS TM H 100



MS - Welding table
TM - Table Tower
H - Height

MS - Mesa de soldadura
TM - Torre mesa
H - Altura

REFERENCE	Referencia	A (IN)	B (IN)	C (IN)	D (IN)	E (IN)	F (IN)	J (IN)	WEIGHT KG (LB)
MS TM Ø 16 H100		100 (3,93)	132 (5,19)	92 (3,62)	31,98 (1,25)	16 (0,62)	134 (5,27)	M8	2,316 (5,10)
MS TM Ø 22 H100		100 (3,93)	132 (5,19)	92 (3,62)	31,98 (1,25)	22 (0,86)	134 (5,27)	M8	2,316 (5,10)
MS TM Ø 28 H100		100 (3,93)	132 (5,19)	92 (3,62)	31,98 (1,25)	28 (1,10)	134 (5,27)	M8	2,316 (5,10)
MS TM Ø 16 H150		150 (5,90)	132 (5,19)	92 (3,62)	31,98 (1,25)	16 (0,62)	134 (5,27)	M9	2,68 (5,90)
MS TM Ø 22 H150		150 (5,90)	132 (5,19)	92 (3,62)	31,98 (1,25)	22 (0,86)	134 (5,27)	M9	2,68 (5,90)
MS TM Ø 28 H150		150 (5,90)	132 (5,19)	92 (3,62)	31,98 (1,25)	28 (1,10)	134 (5,27)	M9	2,68 (5,90)
MS TM Ø 16 H200		200 (7,87)	132 (5,19)	92 (3,62)	31,98 (1,25)	16 (0,62)	134 (5,27)	M10	3,023 (6,66)
MS TM Ø 22 H200		200 (7,87)	132 (5,19)	92 (3,62)	31,98 (1,25)	22 (0,86)	134 (5,27)	M10	3,023 (6,66)
MS TM Ø 28 H200		200 (7,87)	132 (5,19)	92 (3,62)	31,98 (1,25)	28 (1,10)	134 (5,27)	M10	3,023 (6,66)

VERTICAL BASE BASE VERTICAL

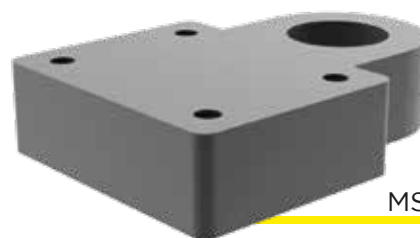
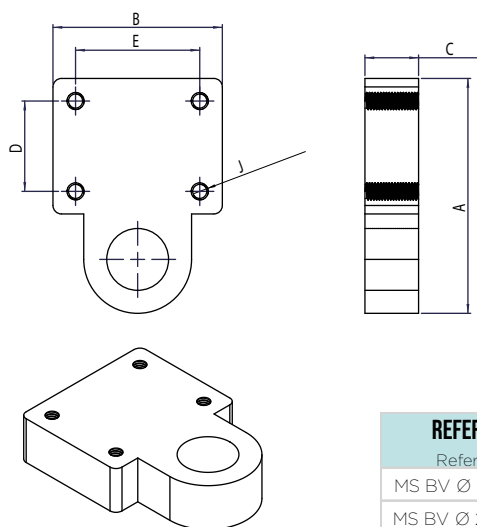

MS BV Ø 22 - KF-011

MS - Welding table
BV - Vertical base

MS - Mesa de soldadura
BV - Base vertical

REFERENCE	Referencia	A (IN)	B (IN)	C (IN)	D (IN)	E (IN)	J (IN)	WEIGHT KG (LB)
MS BV Ø 16 - KF-011		83,2 (3,27)	60 (2,36)	16 (0,62)	32 (1,25)	44 (1,73)	M6	0,48 (1,05)
MS BV Ø 22 - KF-011		83,2 (3,27)	60 (2,36)	19 (0,74)	33 (1,25)	44 (1,73)	M6	0,538 (1,18)
MS BV Ø 28 - KF-011		83,2 (3,27)	60 (2,36)	25,4 (1,00)	34 (1,25)	44 (1,73)	M6	0,673 (1,48)
MS BV Ø 16 - KF-111		97,24 (3,82)	60 (2,36)	16 (0,62)	32 (1,25)	44 (1,73)	M8	0,63 (1,38)
MS BV Ø 22 - KF-111		97,24 (3,82)	60 (2,36)	19 (0,74)	33 (1,25)	44 (1,73)	M8	0,72 (1,58)
MS BV Ø 28 - KF-111		97,24 (3,82)	60 (2,36)	25,4 (1,00)	34 (1,25)	44 (1,73)	M8	0,96 (2,11)

HORIZONTAL BASE BASE HORIZONTAL

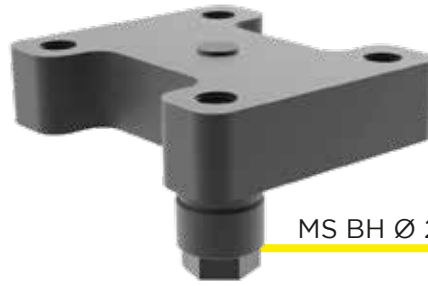
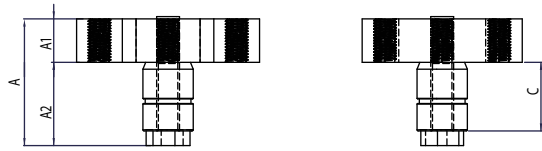

MS BH Ø 22 - KF-052

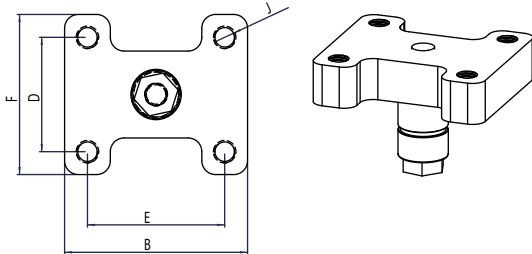

MS BH Ø 22 - KF-0521

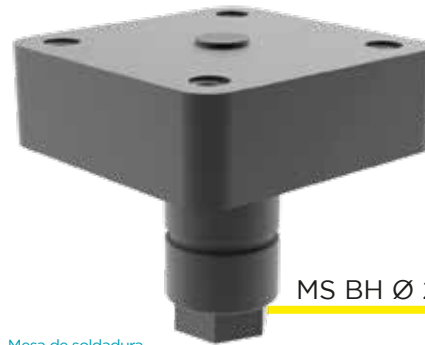
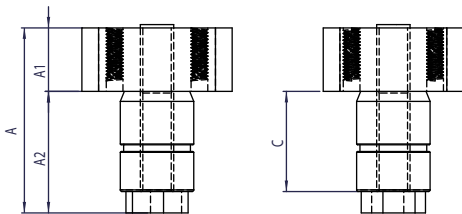

MS BH Ø 22 - KF-532

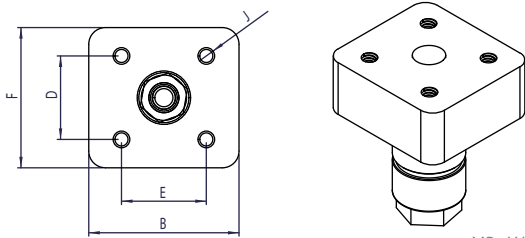

MS - Welding table
BH - Horizontal base

MS - Mesa de soldadura
BH - Base horizontal

REFERENCE Referencia	A (IN)	A1 (IN)	A2 (IN)	B (IN)	C (IN)	D (IN)	E (IN)	F (IN)	J (IN)	WEIGHT KG (LB) Peso
MS BH Ø 16 - KF-052	48,3 (1,90)	16 (0,62)	32,3 (1,27)	80 (3,14)	27 (1,06)	50 (1,96)	60 (2,36)	70 (2,75)	M10	0,56 (1,23)
MS BH Ø 22 - KF-052	55,4 (2,18)	19 (0,74)	36,4 (1,43)	80 (3,14)	30 (1,18)	50 (1,96)	60 (2,36)	71 (2,75)	M10	0,713 (1,57)
MS BH Ø 28 - KF-052	67,9 (2,67)	25,4 (1,00)	42,5 (1,67)	80 (3,14)	35 (1,37)	50 (1,96)	60 (2,36)	72 (2,75)	M10	0,997 (2,19)
MS BH Ø 16 - KF-057	48,3 (1,90)	16 (0,62)	32,3 (1,27)	50 (1,96)	27 (1,06)	35 (1,37)	40 (1,57)	55 (2,16)	M6	0,316 (0,69)
MS BH Ø 22 - KF-057	55,4 (2,18)	19 (0,74)	36,4 (1,43)	50 (1,96)	30 (1,18)	35 (1,37)	40 (1,57)	55 (2,16)	M6	0,43 (0,94)
MS BH Ø 28 - KF-057	67,9 (2,67)	25,4 (1,00)	42,5 (1,67)	50 (1,96)	35 (1,37)	35 (1,37)	40 (1,57)	55 (2,16)	M6	0,62 (1,36)
MS BH Ø 16 - KF-511	48,3 (1,90)	16 (0,62)	32,3 (1,27)	36 (1,41)	27 (1,06)	24 (0,94)	26 (1,02)	37 (1,45)	M6	0,558 (1,23)
MS BH Ø 22 - KF-511	55,4 (2,18)	19 (0,74)	36,4 (1,43)	36 (1,41)	30 (1,18)	24 (0,94)	26 (1,02)	37 (1,45)	M6	0,296 (0,65)
MS BH Ø 28 - KF-511	67,9 (2,67)	25,4 (1,00)	42,5 (1,67)	36 (1,41)	35 (1,37)	24 (0,94)	26 (1,02)	37 (1,45)	M6	0,44 (0,97)
MS BH Ø 16 - KF-521	48,3 (1,90)	16 (0,62)	32,3 (1,27)	45 (1,77)	27 (1,06)	25,4 (1,00)	24 (0,944)	42 (1,65)	M8	0,278 (0,61)
MS BH Ø 22 - KF-521	55,4 (2,18)	19 (0,74)	36,4 (1,43)	46 (1,77)	30 (1,18)	25,4 (1,00)	24 (0,944)	42 (1,65)	M8	0,38 (0,83)
MS BH Ø 28 - KF-521	67,9 (2,67)	25,4 (1,00)	42,5 (1,67)	47 (1,77)	35 (1,37)	25,4 (1,00)	24 (0,944)	42 (1,65)	M8	0,553 (1,21)
MS BH Ø 16 - KF-531	48,3 (1,90)	16 (0,62)	32,3 (1,27)	50 (1,96)	27 (1,06)	32 (1,25)	37 (1,45)	55 (2,16)	M10	0,363 (0,80)
MS BH Ø 22 - KF-531	55,4 (2,18)	19 (0,74)	36,4 (1,43)	50 (1,96)	30 (1,18)	32 (1,25)	37 (1,45)	55 (2,16)	M10	0,483 (1,06)
MS BH Ø 28 - KF-531	67,9 (2,67)	25,4 (1,00)	42,5 (1,67)	50 (1,96)	35 (1,37)	32 (1,25)	37 (1,45)	55 (2,16)	M10	0,691 (1,52)
MS BH Ø 16 - KF-532	48,3 (1,90)	16 (0,62)	32,3 (1,27)	57 (2,24)	27 (1,06)	41 (1,61)	42 (1,65)	58 (2,28)	M10	0,442 (0,97)
MS BH Ø 22 - KF-532	55,4 (2,18)	19 (0,74)	36,4 (1,43)	58 (2,24)	30 (1,18)	41 (1,61)	42 (1,65)	58 (2,28)	M10	0,577 (1,27)
MS BH Ø 28 - KF-532	67,9 (2,67)	25,4 (1,00)	42,5 (1,67)	59 (2,24)	35 (1,37)	41 (1,61)	42 (1,65)	58 (2,28)	M10	0,817 (1,80)
MS BH Ø 16 - KF-533	48,3 (1,90)	16 (0,62)	32,3 (1,27)	49 (1,92)	27 (1,06)	41 (1,61)	36 (1,41)	50 (1,96)	M8	0,448 (0,98)
MS BH Ø 22 - KF-533	55,4 (2,18)	19 (0,74)	36,4 (1,43)	49 (1,92)	30 (1,18)	41 (1,61)	36 (1,41)	50 (1,96)	M8	0,583 (1,28)
MS BH Ø 28 - KF-533	67,9 (2,67)	25,4	42,5 (1,67)	49 (1,92)	35 (1,37)	41 (1,61)	36 (1,41)	50 (1,96)	M8	0,824 (1,81)

SQUEEZE ACTION CLAMPS ALICATES

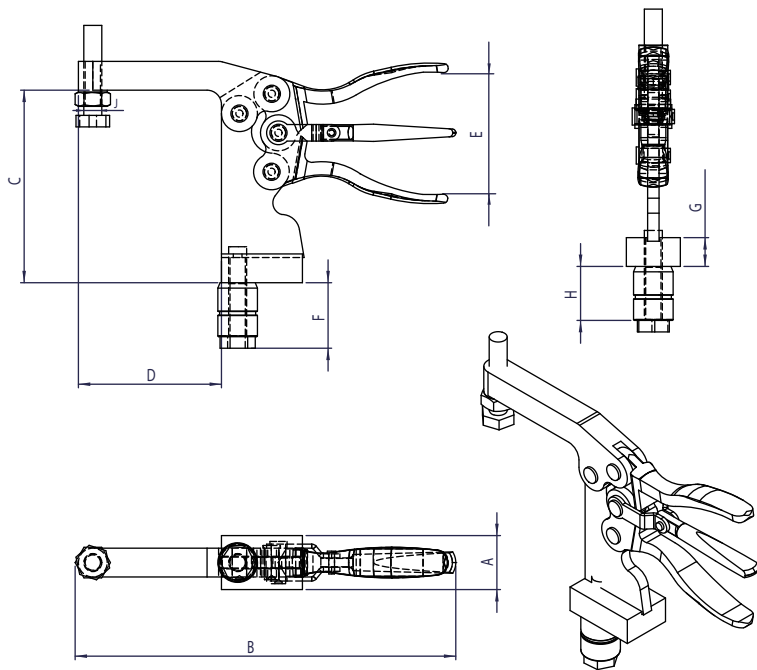

KFA-200 MS Ø 22



MS - Welding table

MS - Mesa de soldadura

REFERENCE Referencia	A (IN)	B (IN)	C (IN)	D (IN)	E (IN)	F (IN)	G (IN)	H (IN)	J (IN)	WEIGHT KG (LB) Peso
KFA-200 MS Ø 16	30 (1,18)	212 (8,34)	107,52 (4,23)	79,5 (3,12)	58 (2,28)	32,3 (1,27)	16 (0,62)	27 (1,06)	M10	0,945 (2,08)
KFA-200 MS Ø 22	30 (1,18)	212 (8,34)	107,52 (4,23)	79,5 (3,12)	58 (2,28)	32,3 (1,27)	16 (0,62)	30 (1,18)	M10	1,007 (2,22)
KFA-200 MS Ø 28	30 (1,18)	212 (8,34)	107,52 (4,23)	79,5 (3,12)	58 (2,28)	32,3 (1,27)	16 (0,62)	35 (1,37)	M10	1,094 (2,41)

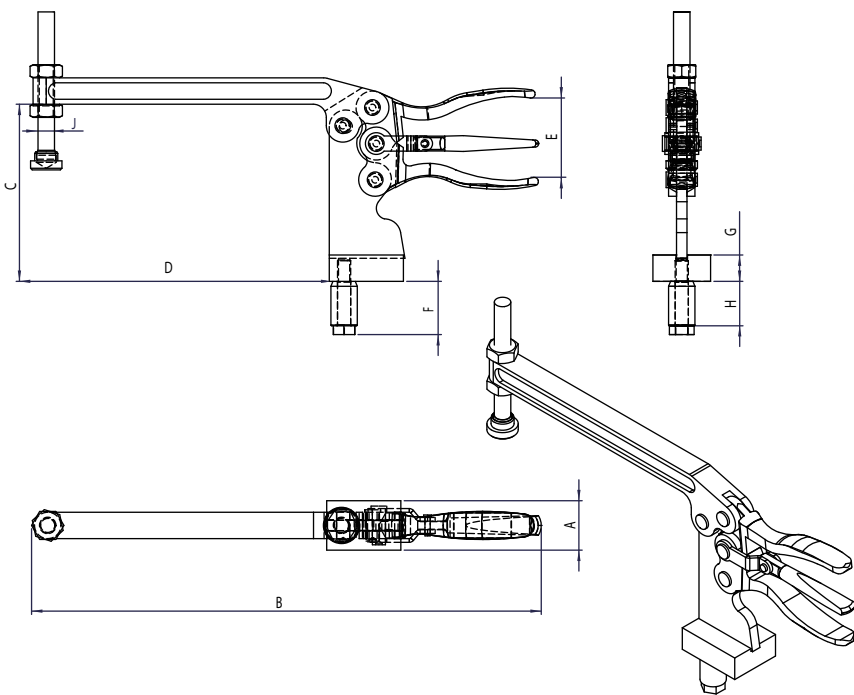

KFA-200 L MS Ø 22



MS - Welding table
L- Long U-Bar

MS - Mesa de soldadura
L- Lock Plus

REFERENCE Referencia	A (IN)	B (IN)	C (IN)	D (IN)	E (IN)	F (IN)	G (IN)	H (IN)	J (IN)	WEIGHT KG (LB) Peso
KFA-200 L MS Ø 16	30 (1,18)	307 (12,08)	107,52 (4,23)	179,79 (7,07)	58 (2,28)	32,3 (1,27)	16 (0,62)	27 (1,06)	M10	1,129 (2,48)
KFA-200 L MS Ø 22	30 (1,18)	307 (12,08)	107,52 (4,23)	179,79 (7,07)	58 (2,28)	32,3 (1,27)	16 (0,62)	30 (1,18)	M10	1,18 (2,60)
KFA-200 L MS Ø 28	30 (1,18)	307 (12,08)	107,52 (4,23)	179,79 (7,07)	58 (2,28)	32,3 (1,27)	16 (0,62)	35 (1,37)	M10	1,266 (2,79)

AGILITY FOR YOUR PROCESS

AGILIDAD PARA SU PROCESO

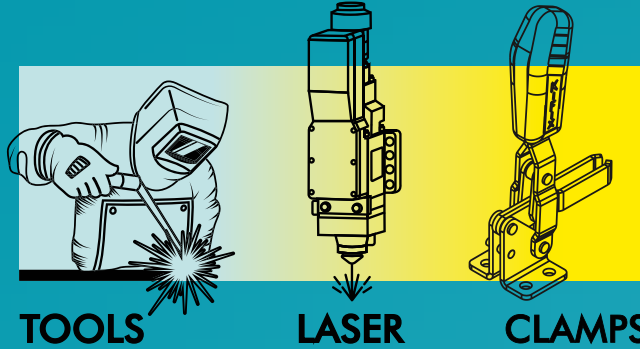

Kifix[®]

GROUP



ACCESS / ACCESO :



KIFIX INDÚSTRIA E COMÉRCIO LTDA.

Phone/ Teléfono: +55 54 3028.4614/3028.4615 | kifix@kifix.com.br

Street /Calle: Gov. Roberto Silveira, 899 - Santa Catarina

ZIP CODE/CEP 95032-710 - Caxias do Sul | RS | Brazil / Brasil